

Contents of Work Package 3-WP11 Vehicle Instrumentation, Testing and Life Cycle Monitoring

3-WP11: Vehicle Instrumentation, Testing and Life Cycle Monitoring

Coordinator of the WP

Brno University of Technology - Ing. Kamil Řehák, Ph.D.

Participants of the WP

Brno University of Technology – Ing. Kamil Řehák, Ph.D., Ing. Aleš Prokop, Ph.D., prof. Ing. Václav Píštěk, DrSc., doc. Ing. Pavel Kučera, Ph.D.; Zetor Tractors a.s. – Ing. Stanislav Mitáš, Ph.D; Tatra Trucks a.s – Ing. Martin Frait; West Bohemia University – Ing. Pavel Žlábek, Ph.D., Technical university Ostrava – Ing. Miroslav Trochta, Ph.D.

Main Goal of the WP

Development of approach to increase repeatability of measurement which significantly affect results of technical experiments.

Partial Goals for the Current Period

Perform initial concept study, initial measurement, create computational models and perform initial multiphysics simulation.

Contents of Work Package 3-WP11 Vehicle Instrumentation, Testing and Life Cycle Monitoring

3-WP11: Vehicle Instrumentation, Testing and Life Cycle Monitoring

Official 3-WP11 Deliverables:

- 3-WP11-001 | **Instrumented tractor for monitoring**, G-funk, ZETOR 0.7; BUT 0.2; TUO 0.05; WBU 0.05
- 3-WP11-002 | **Knowledge database of operation conditions and their influencing of tractor components lifecycle**, G-funk, ZETOR 0.3; BUT 0.3; TUO 0.2; WBU 0.2
- 3-WP11-003 | **Virtual driver for exact experiment repeatability**, G-funk, BUT 0.85; TATRA 0.10; WBU 0.05



Activities in 3-WP11 Vehicle Instrumentation, Testing and Life Cycle Monitoring

3-WP11-001: Instrumented tractor for monitoring

- Determination of profile for testing
 - determination of tractor including accessories
 - determination strategy for testing
 - determination of sensors position
- Perform initial measurement
- Perform stress strain analysis to detect position for sensors
 - Critical operational condition
- Evaluate data from technical experiment
 - creation of database

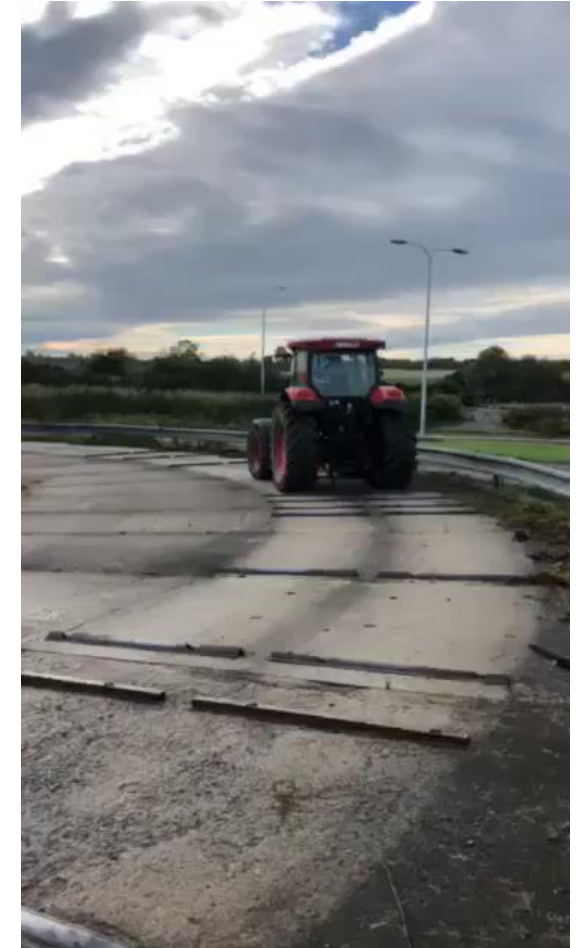

Activities in 3-WP11 Vehicle Instrumentation, Testing and Life Cycle Monitoring

3-WP11-001: Instrumented tractor for monitoring

- Initial instrumentation of tractor for monitoring
 - Body
 - Cabin + seat
 - Front axle
- Perform FEA
 - Fall on the front wheels
 - Torsion of tractor bod
 - Driving on the rear wheels

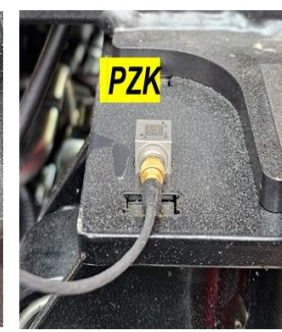
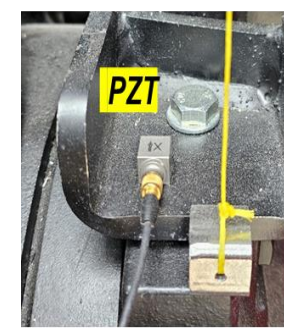
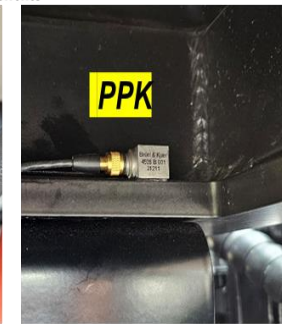
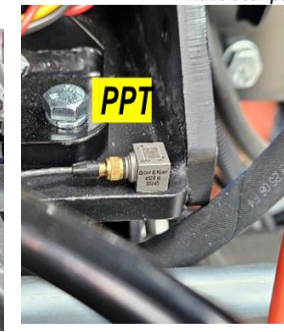
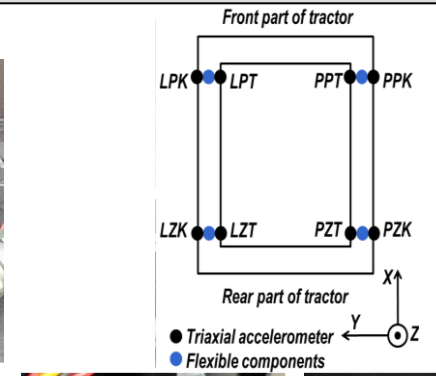
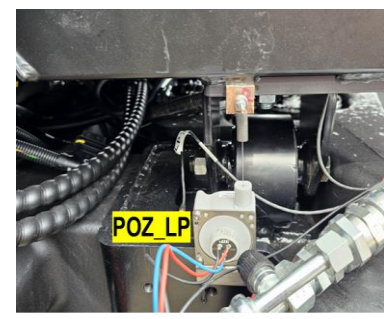
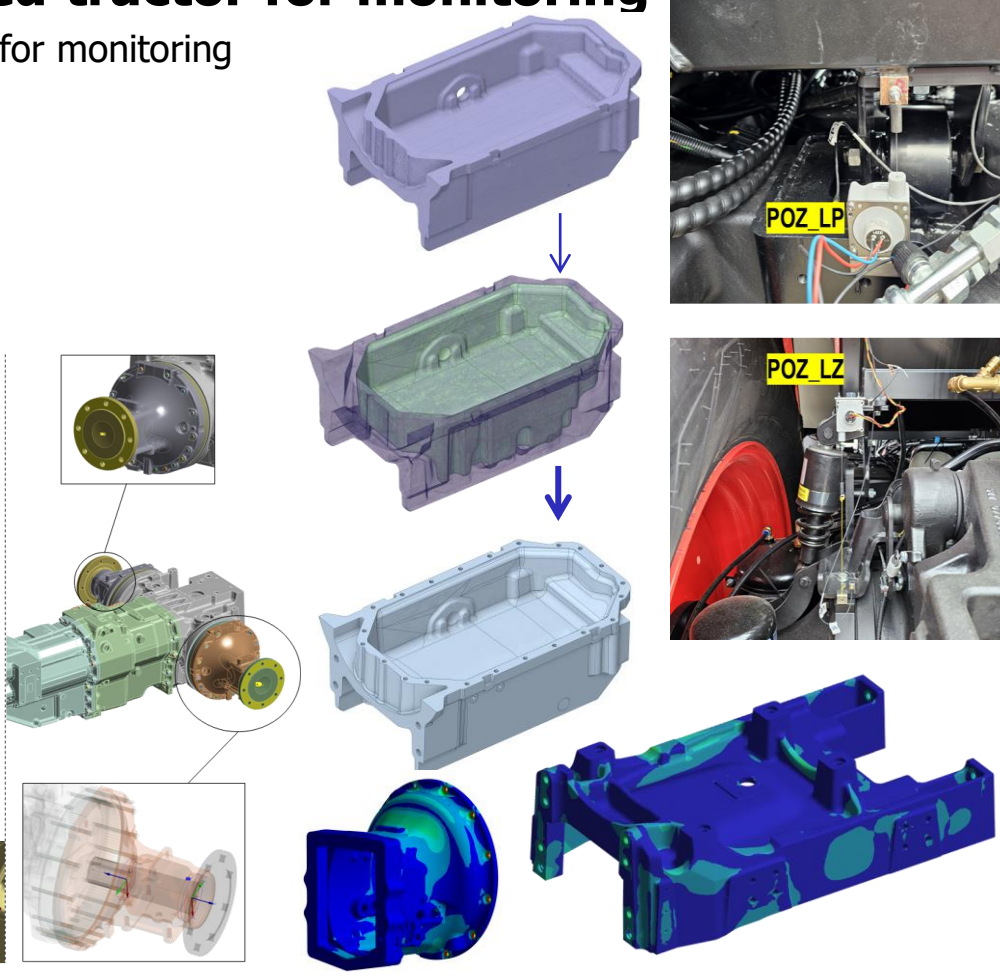
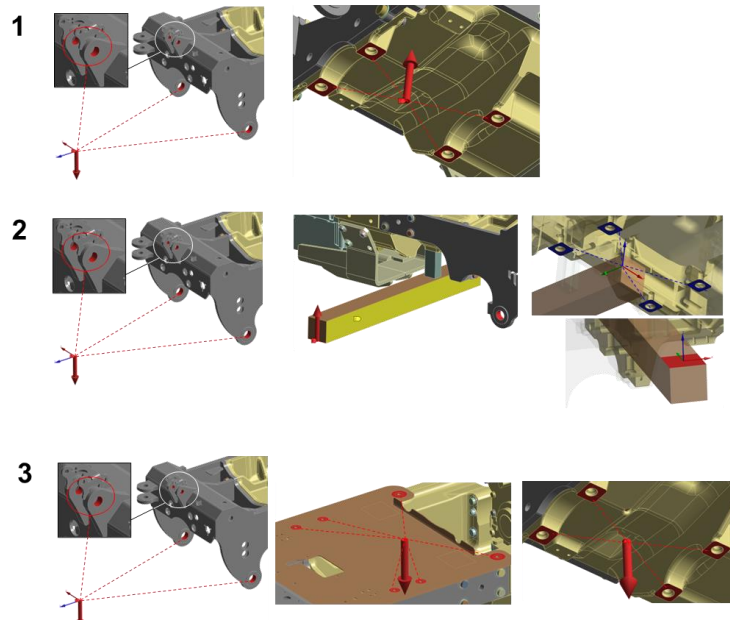

Activities in 3-WP11 Vehicle Instrumentation, Testing and Life Cycle Monitoring

3-WP11-001: Instrumented tractor for monitoring

- Data processing - Creation of approach which enables to real time processing and comparison of results

- Web application in Python
- Parsing all common formats xls/x, .csv, .xml, .mat, .hdf5
- Possible cloud deployment
- Possible communication with Matlab

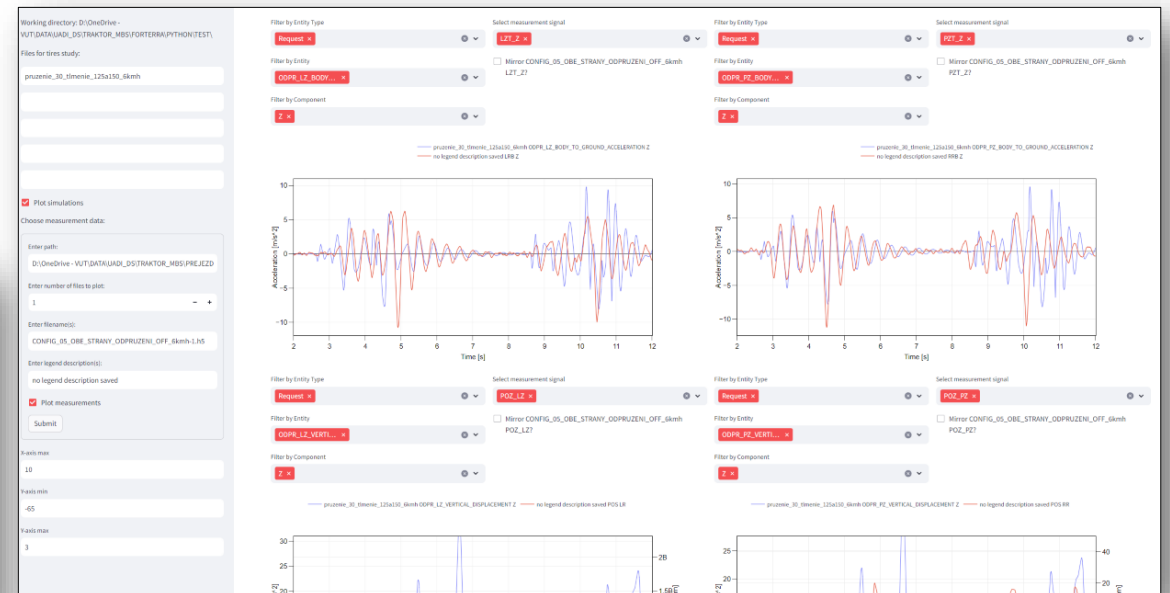
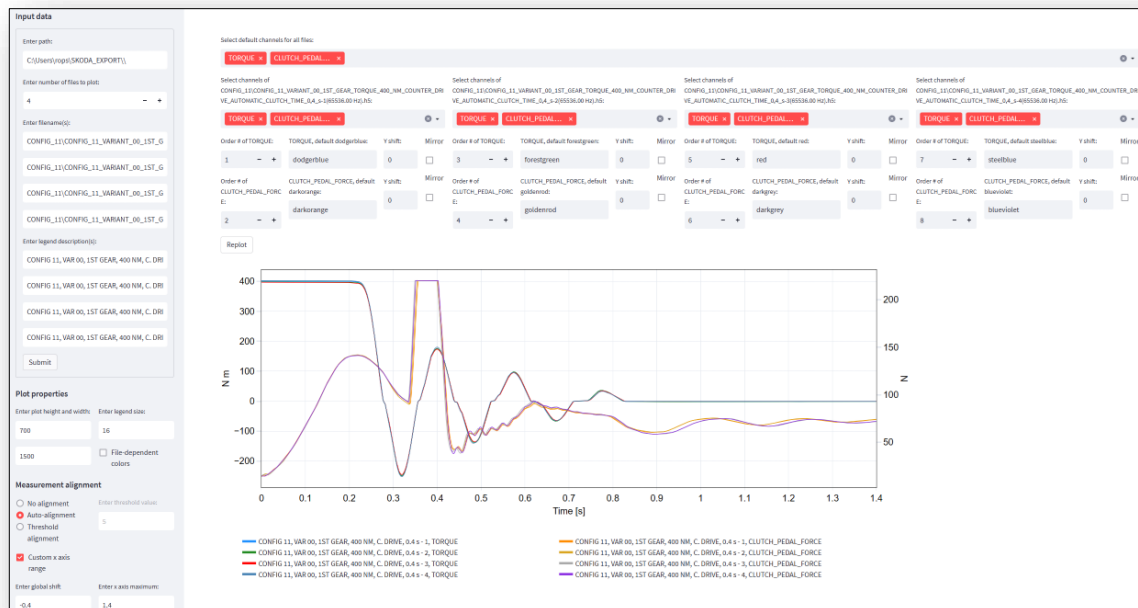

- Interactive data filtering
- Interactive graphs
- Drag and Drop data/axes/scales shifting
- Comments, sketching
- High resolution picture export

Activities in 3-WP11 Integration of Multiphysics Simulations and Digital Twins Technologies into Design Assistance System and Operation Reliability

3-WP11-002: Knowledge database of operation conditions and their influencing of tractor components lifecycle

- Determination of maximal loading of tractor

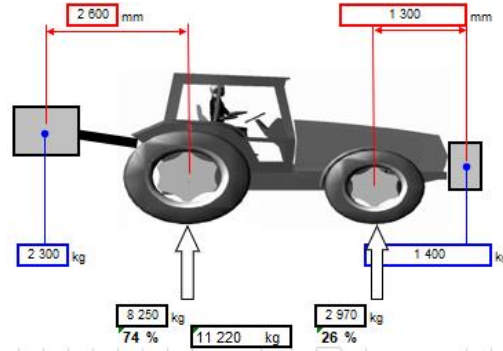

- Determine the scenario and operational condition in the field vs. on the test rig.
- The most simple test.
- Effect of speed.
- Investigation of tyre pressure influence



Activities in 3-WP11 Vehicle Instrumentation, Testing and Life Cycle Monitoring

3-WP11-002: Knowledge database of operation conditions and their influencing of tractor components lifecycle

- Determine the scenario and operational condition in the field vs. on the test rig.
- Evaluation and processing of data from technical experiment.
- Connection to the operator
- Evaluation of repeatability
- Data evaluation
- Determination of suitability for further testing

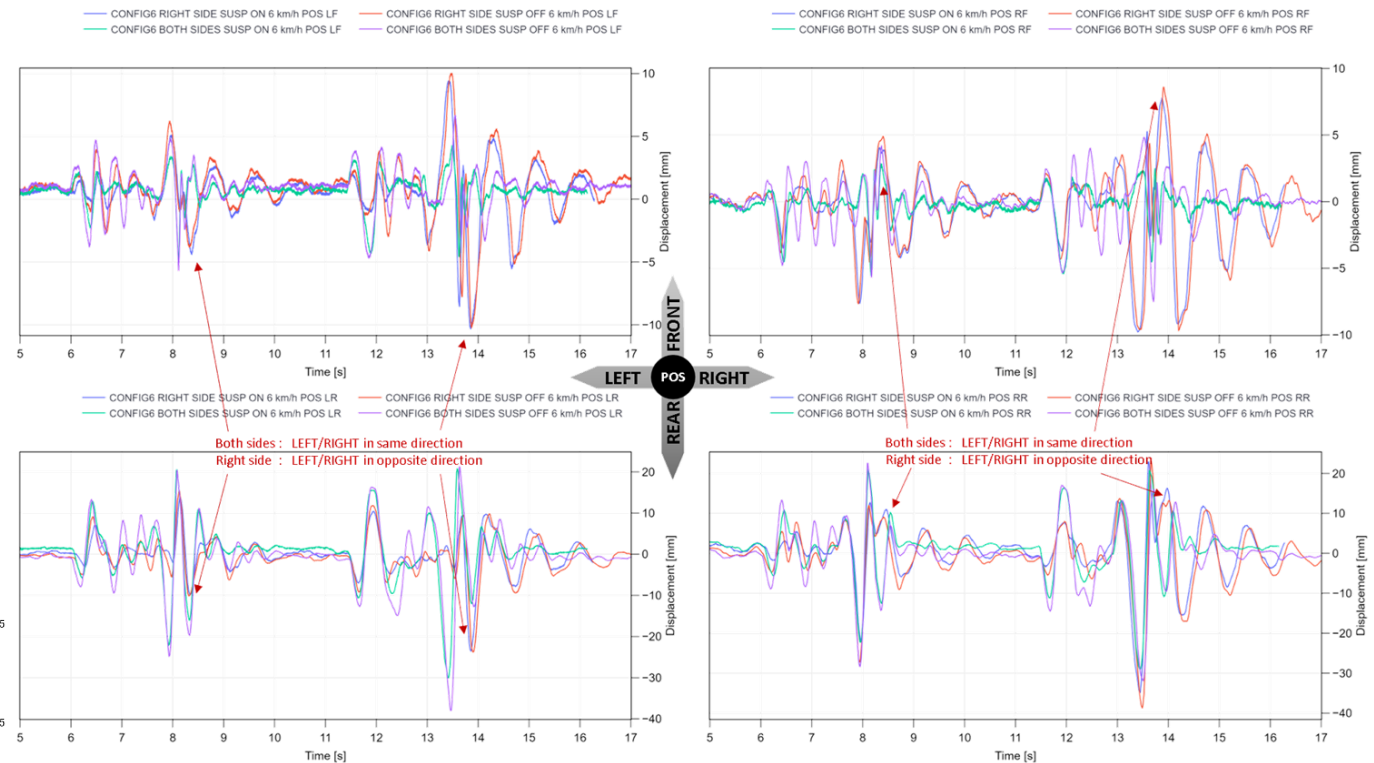
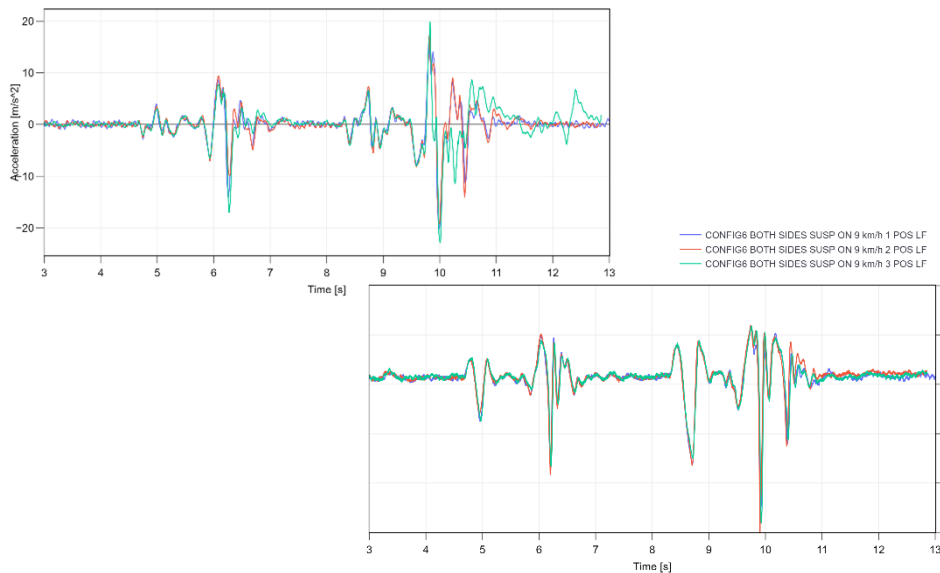

Activities in 3-WP11 Vehicle Instrumentation, Testing and Life Cycle Monitoring

3-WP11-003: Virtual driver for exact experiment repeatability

- First stage (priority):
 - ECU design for automated control according to the test
 - Truck Engine Control
 - Detection of the position of the vehicle relative to the test track (optical barriers, markings on the test track)
- Second phase:
 - Expanding elements of autonomy
 - Engine control
 - Braking control
 - Control mechanisms and supplemented by sensors for detection
 - Building a complex hardware chain
 - Extension with ECU with GPU for implementation of Deep learning (detection)
- Objectives and benefits
 - Ease of implementation on different vehicles
 - Repeatability of measurements
 - Better comparison of measured noise data - separation of driver influence
 - Automation/Autonomy to reduce personnel demands
 - Extending the project into autonomous vehicle control, possible use in other areas

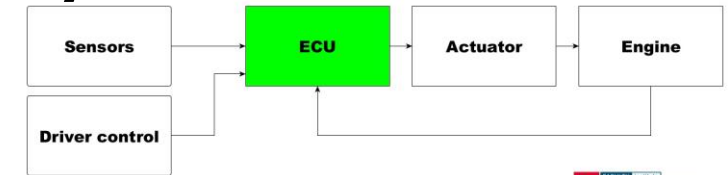

FACULTY Institute
OF MECHANICAL ENGINEERING
Contact: Pavel Kučera (BUT)
kucera@fme.vutbr.cz

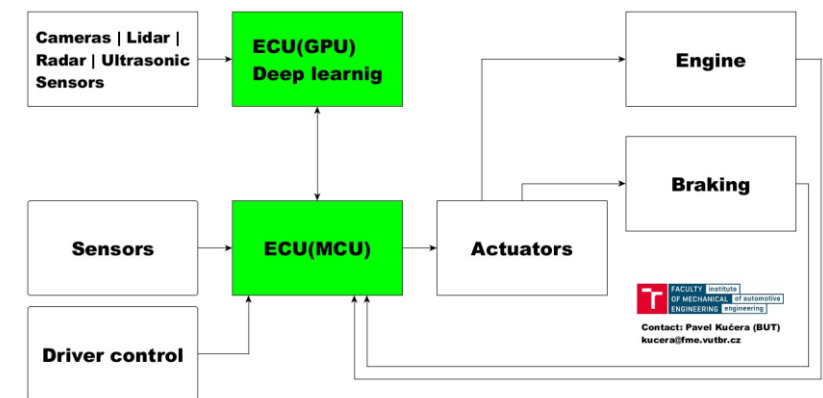

FACULTY Institute
OF MECHANICAL ENGINEERING
Contact: Pavel Kučera (BUT)
kucera@fme.vutbr.cz

Activities in 3-WP11 Vehicle Instrumentation, Testing and Life Cycle Monitoring

3-WP11-003: Virtual driver for exact experiment repeatability

- Hardware concept - ECU
 - Automotive standard
 - SPC5xx
 - CAN Transceiver
 - DIO
 - Power supply
 - Control mechanisms (driver switch)
 - Software interface (new program, parameters, diagnostic)

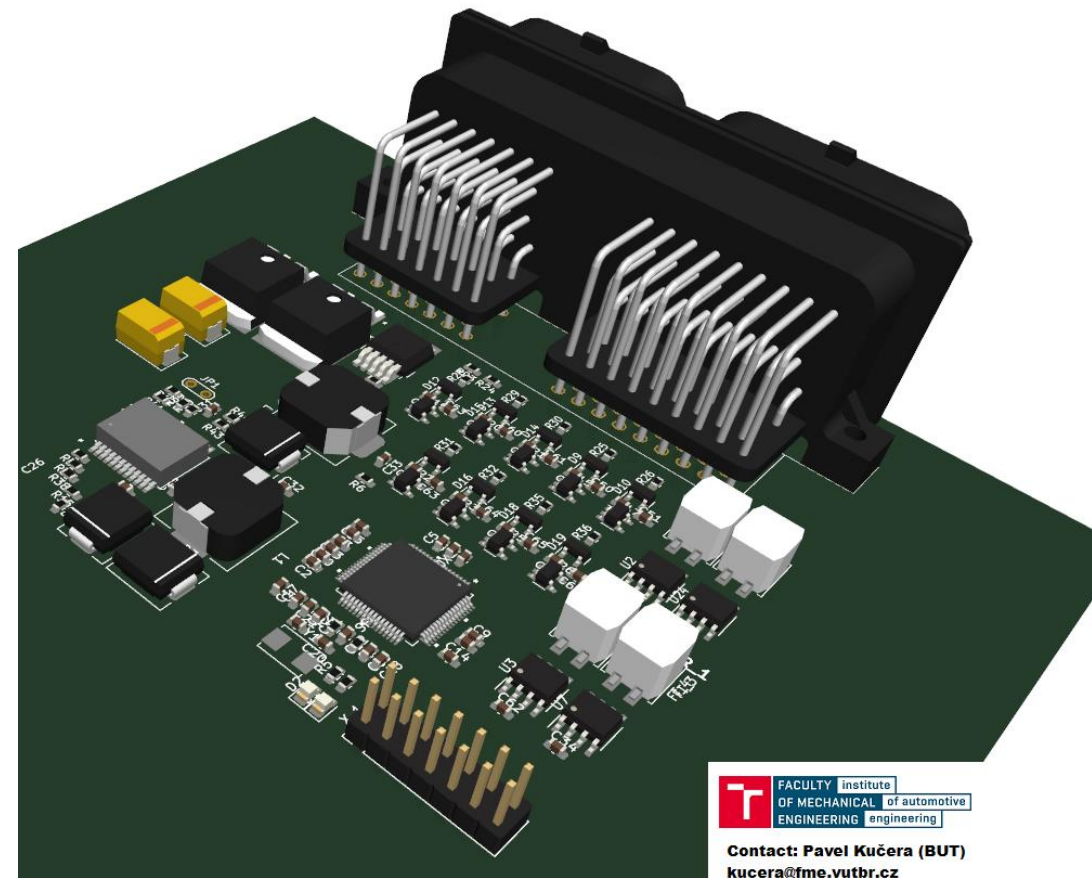

Fulfillment of goals and deliverables of 3-WP11 Vehicle Instrumentation, Testing and Life Cycle Monitoring

Current State of Deliverables, Milestones and Fulfillment of Goals

- 3-WP11-001 | Instrumented tractor for monitoring, ZETOR 0.7; BUT 0.2; TUO 0.05; WBU 0.05 **in progress & no major delays:**
 - Initial technical experiments were performed, the strategy and approach to results evaluation were established.
- 3-WP11-002 | Knowledge database of operation conditions and their influencing of tractor components lifecycle, ZETOR 0.3; BUT 0.3; TUO 0.2; WBU 0.2 **in progress & no major delays:**
 - the strategy and approach to results evaluation were established, results from technical experiment were evaluated.
- 3-WP11-003 | Virtual driver for exact experiment repeatability, G-funk, BUT 0.85; TATRA 0.10; WBU 0.05 **in progress & no major delays:**
 - The concept for the virtual driver was laid out, the ECU design and other follow-up work started to fulfill the output

Fulfillment of goals and deliverables of 3-WP11 Vehicle Instrumentation, Testing and Life Cycle Monitoring

List of Due Deliverables and Their Added Value

- **3-WP11-001 - Instrumented tractor for monitoring** enables to monitor behaviour of tractor during whole spectrum of operation conditions and based on this set appropriate servis interval and decrease servise costs.
- **3-WP11-002 - Knowledge database of operation conditions and their influencing of tractor components lifecycle** extends knowledge of current tractor operations conditions including effect on the lifetime. It enables to set appropriate servis interval and decrease servise costs.
- **3-WP11-003 - Virtual driver for exact experiment repeatability** enables the reduction of costs and the increase of competitiveness of capabilities.

Current contribution of 3-WP11 Vehicle Instrumentation, Testing and Life Cycle Monitoring

Assessment of the Contribution of Deliverables

Financial resources are used according the project plan and the share of commercialization is also met. Based on the cooperation the proposal for new project are prepared or under assesment.



Current contribution of 3-WP11 Vehicle Instrumentation, Testing and Life Cycle Monitoring

Assessment of the Formal/Administrative Goals of the Work Package

	BUT	ZETOR TRACTORS	TATRA TRUCKS	TUO	WBU
Finances (reporting/spending)	OK	OK	OK	OK	OK
Commercialization (the whole organisation)	OK	OK	OK	OK	OK
Deliverables	OK	OK	OK	OK	OK

Current contribution of 3-WP11 Vehicle Instrumentation, Testing and Life Cycle Monitoring

Acknowledgment

This research has been realized using the support of Technological Agency, Czech Republic, programme National Competence Centres II, project # TN02000054 Božek Vehicle Engineering National Center of Competence (BOVENAC).

Výtah z prací 2023-2025 na 3-WP11 Přístrojové vybavení vozidel, testování a monitorování životního cyklu

3-WP11-003 Virtuální řidič pro přesnou opakovatelnost experimentu

(Pavel Kučera – kucera@fme.vutbr.cz)

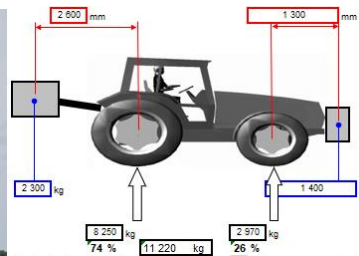
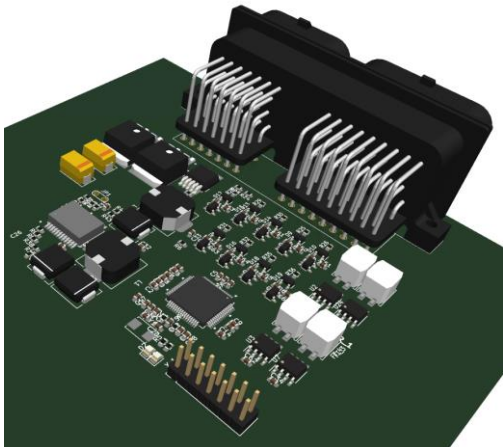
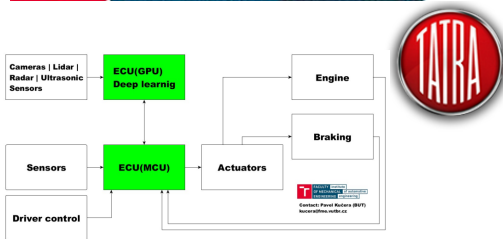

3-WP11-001 Instrumentovaný traktor pro monitorování

3-WP11-002 Znalostní databáze provozních podmínek a jejich vliv na životnost komponent traktoru

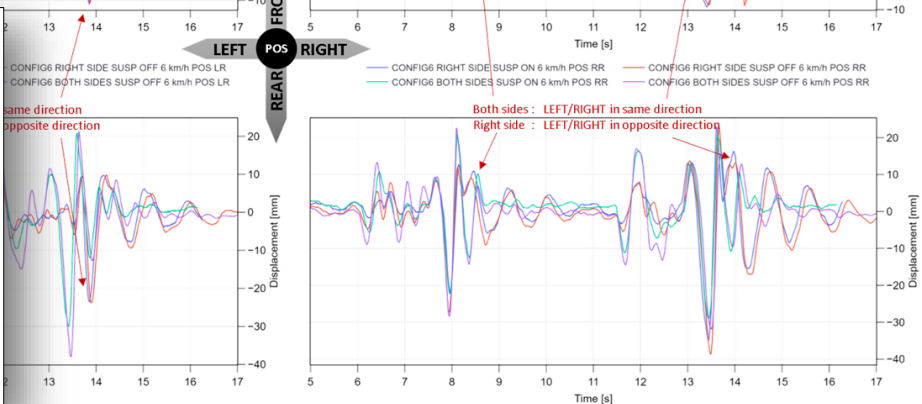
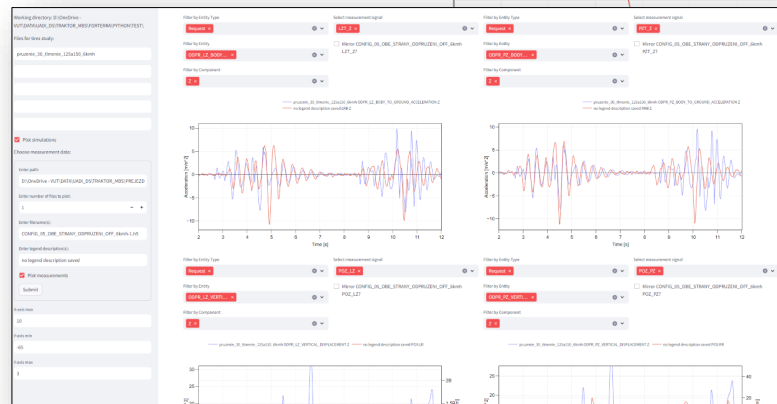
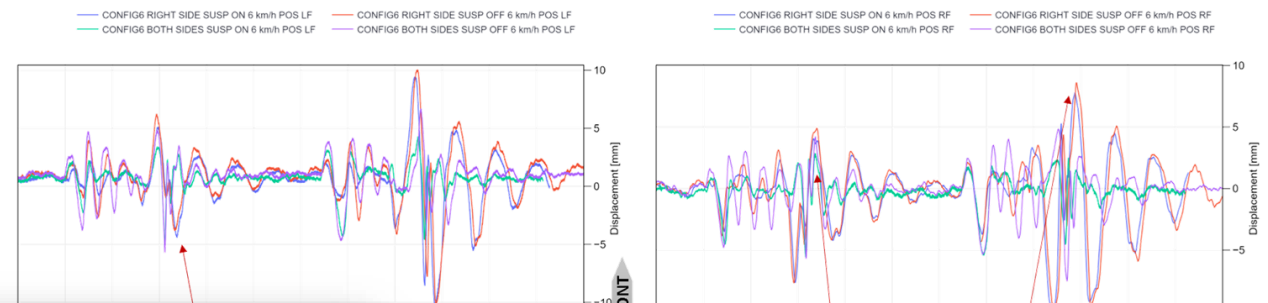

Results of 3-WP11 Vehicle Instrumentation, Testing and Life Cycle Monitoring–Achieved 2023-2025

3-WP11-003 Virtual driver for exact experiment repeatability
(Pavel Kučera – kucera@fme.vutbr.cz)

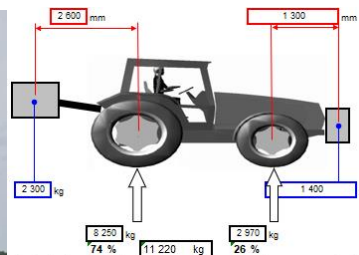
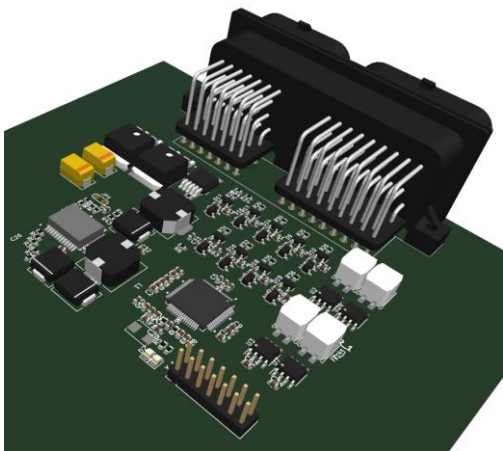
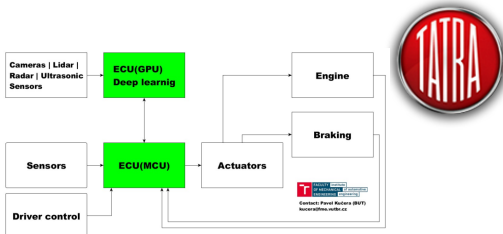

3-WP11-001 Instrumented tractor for monitoring
3-WP11-002 Knowledge database of operation conditions and their influencing of tractor components lifecycle

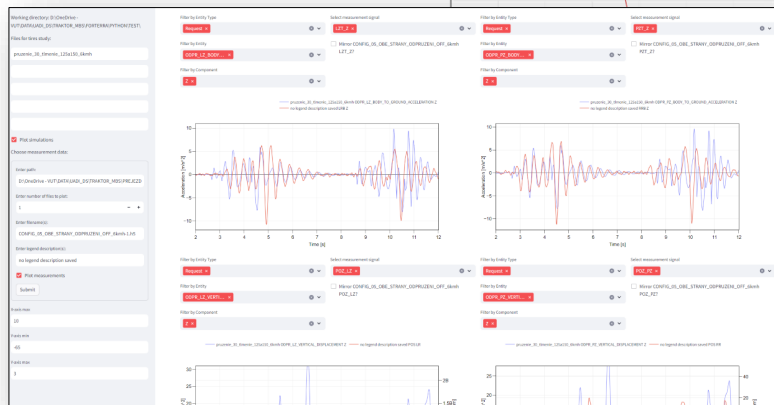
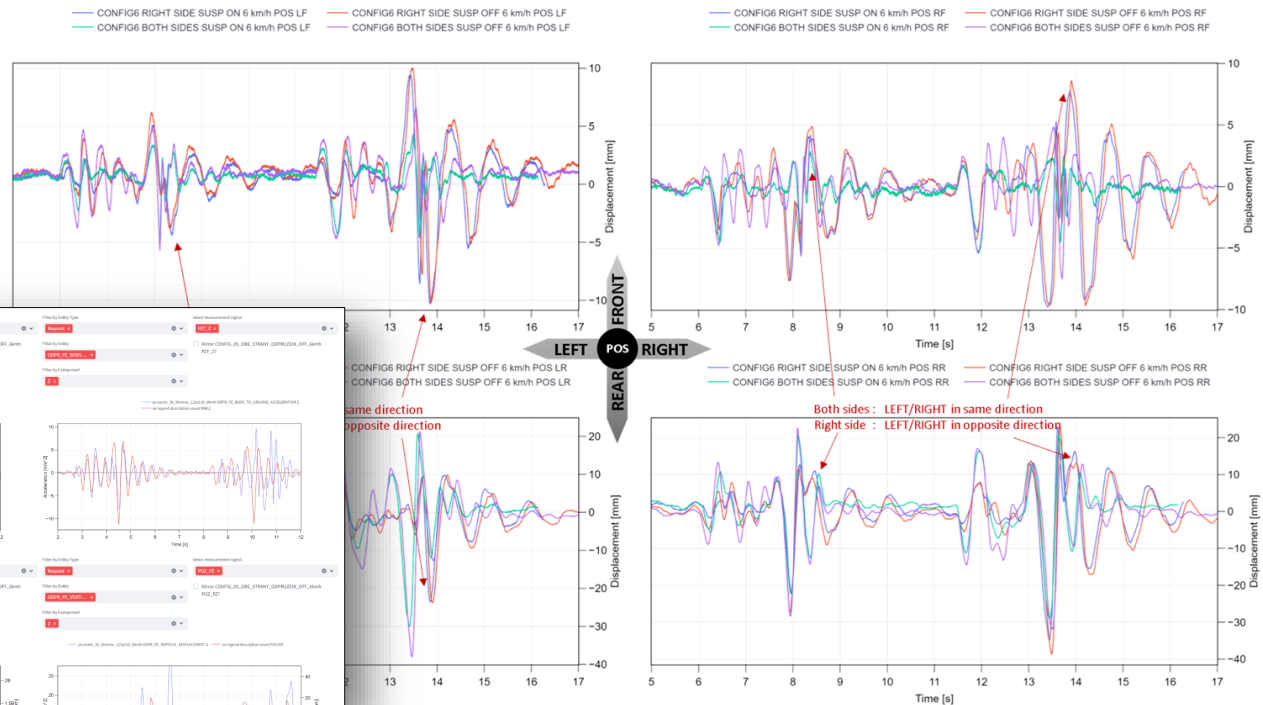

Výtah z prací 2023 na 3-WP11 Přístrojové vybavení vozidel, testování a monitorování životního cyklu

3-WP11-003 Virtuální řidič pro přesnou opakovatelnost experimentu

(Pavel Kučera – kucera@fme.vutbr.cz)

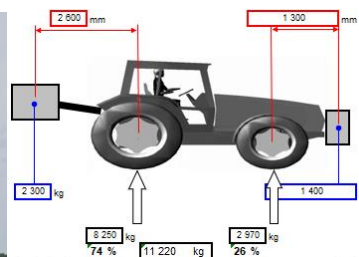
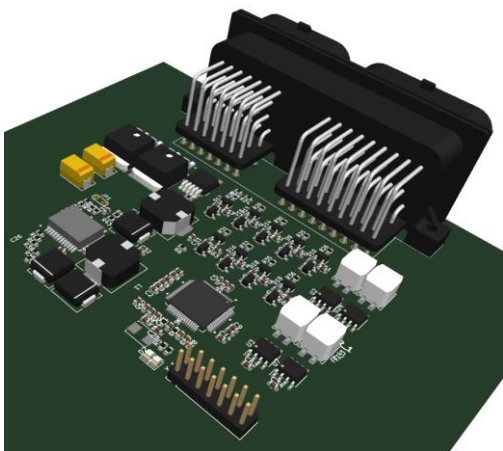
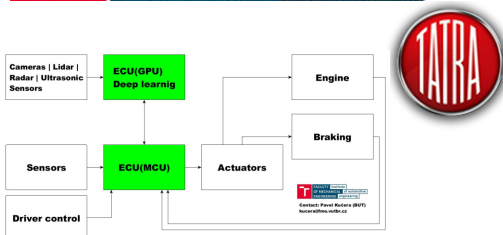

3-WP11-001 Instrumentovaný traktor pro monitorování

3-WP11-002 Znalostní databáze provozních podmínek a jejich vliv na životnost komponent traktoru

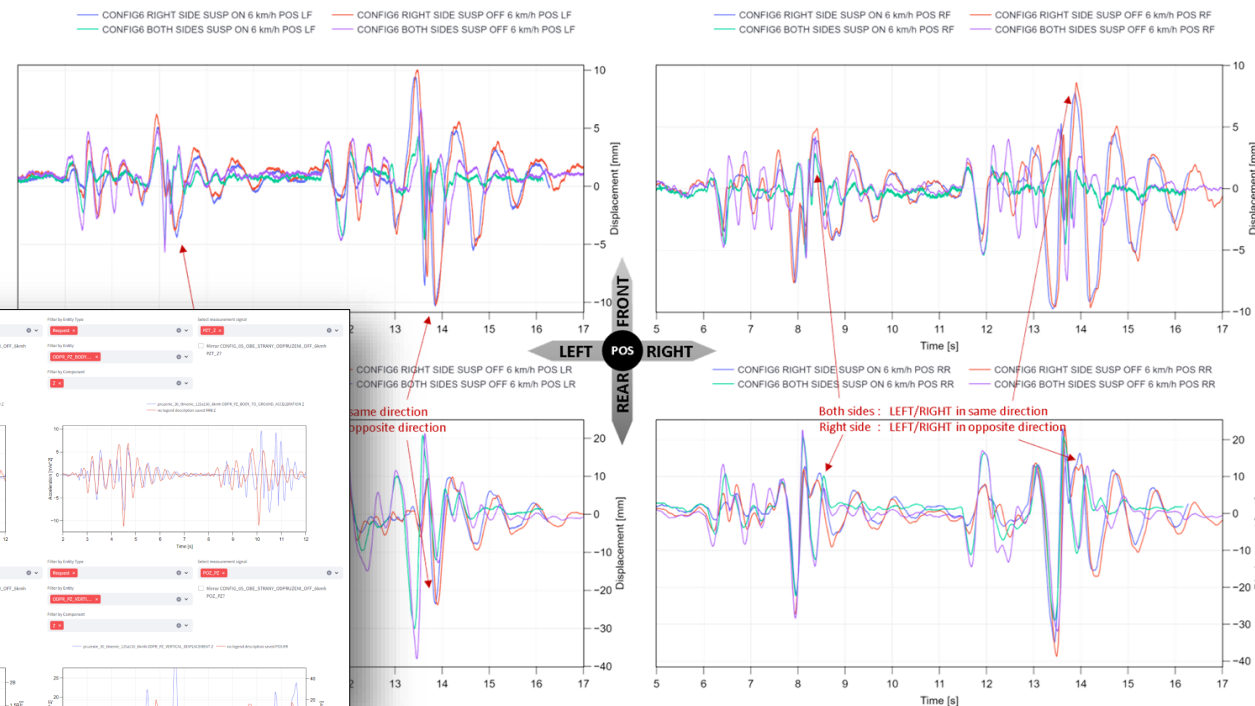

Results of 3-WP11 Vehicle Instrumentation, Testing and Life Cycle Monitoring–Achieved 2023

3-WP11-003 Virtual driver for exact experiment repeatability
(Pavel Kučera – kucera@fme.vutbr.cz)

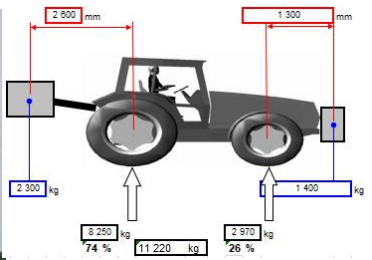
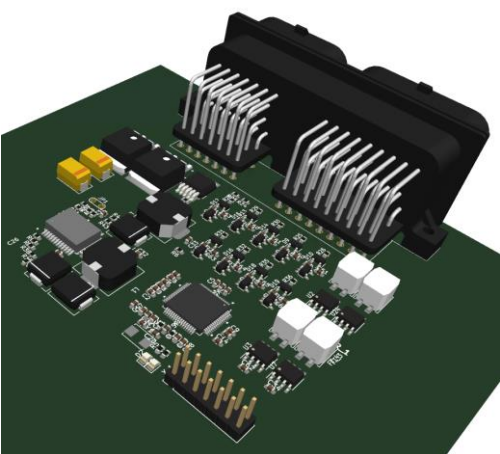
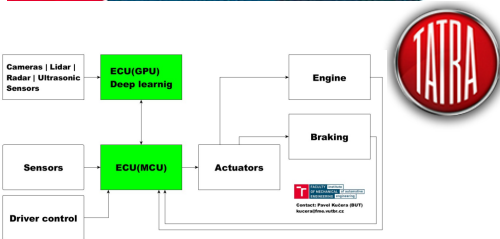

3-WP11-001 Instrumented tractor for monitoring
3-WP11-002 Knowledge database of operation conditions and their influencing of tractor components lifecycle

